

**SOLATUBE 300DS-C-DAI-FP-TM-LN**  
**(14 IN / 355 MM)**  
**PITCHED SELF FLASHING**  
**SUSPENDED CEILING**

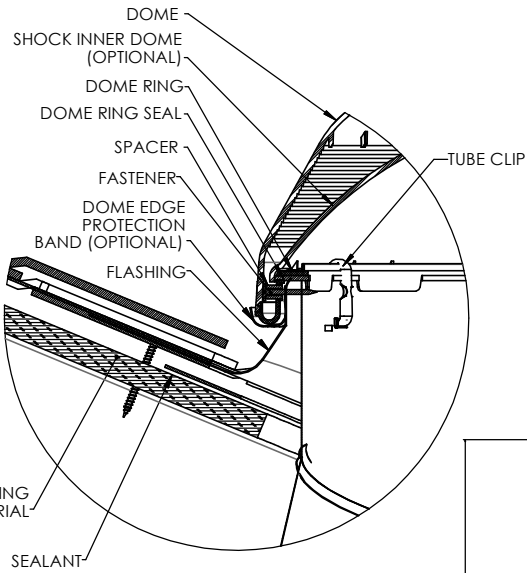

**DETAIL B**  
**SCALE 3 : 1**

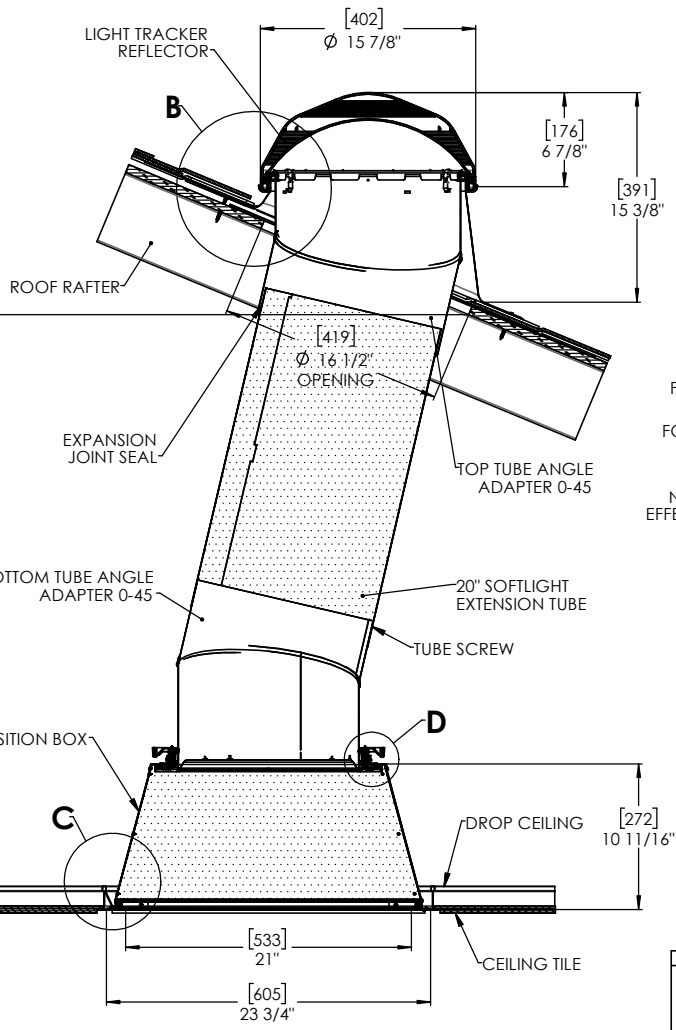

**FULL SECTION**  
**SCALE 1:1**

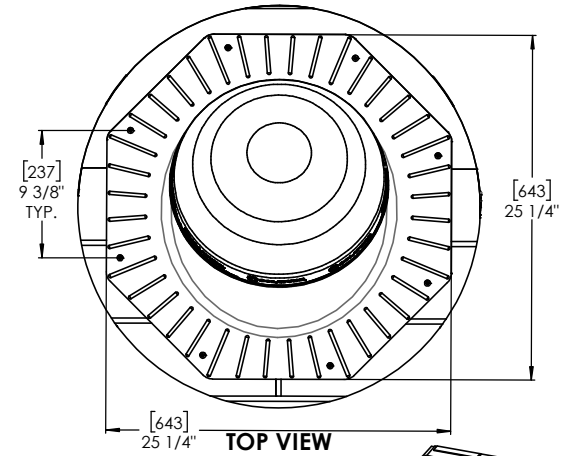

**TOP VIEW**

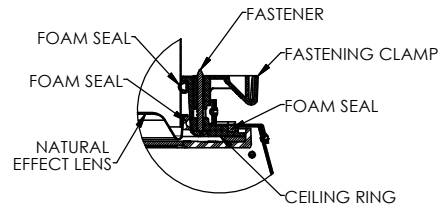

**DETAIL D**  
**SCALE 3 : 1**

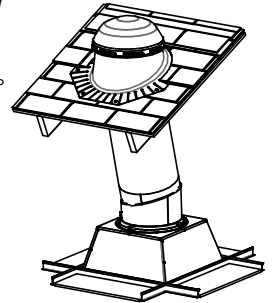

**NOTES:**

1. STRUCTURAL ELEMENTS (PLYWOOD, RAFTERS, DRYWALL ETC.) BY OTHERS & SHOWN FOR REFERENCE ONLY.
2. ALL TUBE JOINTS & SEAMS TAPED WITH 2" FOIL TAPE (NOT SHOWN).
3. DIMENSIONS IN BRACKETS ARE METRIC UNLESS OTHERWISE SPECIFIED.
4. 6" MIN CLEARANCE SHOULD BE MAINTAINED FROM ALL SOLATUBE COMPONENTS AND OTHER PLENUM COMPONENTS.
5. 30" MIN HEIGHT NEEDED FOR TRANSITION BOX
6. ONE (1) SOFTLIGHT EXTENSION TUBE PER DAYLIGHTING SYSTEM. MUST INSTALL AS FINAL EXTENSION TUBE PRIOR TO THE BOTTOM (ANGLE) TUBE.

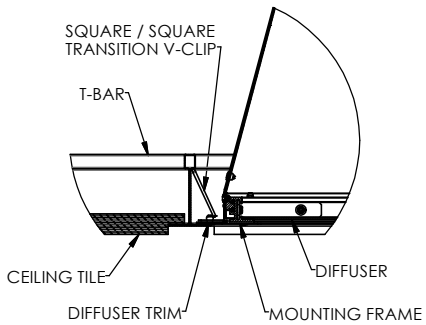

**DETAIL C**  
**SCALE 3 : 1**

UNLESS OTHERWISE SPECIFIED:		<b>SOLATUBE</b> <small>2215 OAK RIDGE HWY          COSTA MESA, CALIFORNIA 92626-1841          PH (714) 597-4600</small>	
DIMENSION TOLERANCE FRACTIONS ± 1/4" DECIMALS ± .06 INCH MILLIMETER XX ± .06 1X ± 1.5		<b>SOLATUBE INTERNATIONAL INC.</b> COPYRIGHT 2017 WWW.SOLATUBE.COM	
MATERIAL	-	DRAWN BY	STEVENS
FINISH	-	DATE	3/17/17
		CHECKED BY	-
		DATE	-
		APPROVED BY	-
		DATE	-
DO NOT SCALE DRAWING			
		SIZE	D
		DWG. NO.	300DS-C-DAI-FP-TM-LN
		REV	2
		SCALE	1:1
		SHEET 1 OF 1	