

SOLATUBE 300DS-C-DAI-F6-TM-LN
(14 IN / 355 MM)
SELF-FLASHING
SUSPENDED CEILING

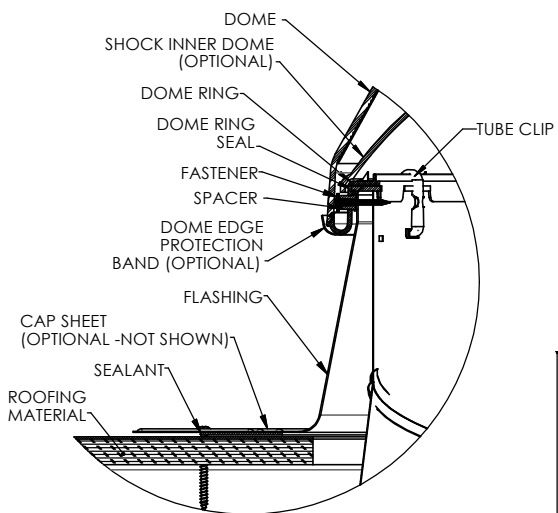

DETAIL B
SCALE 3 : 1

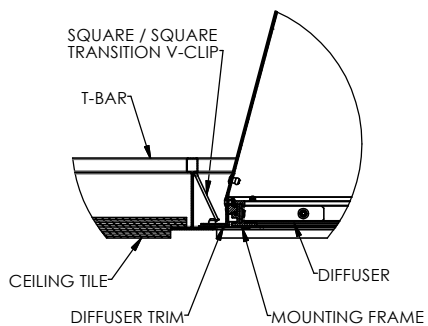

DETAIL C
SCALE 3 : 1

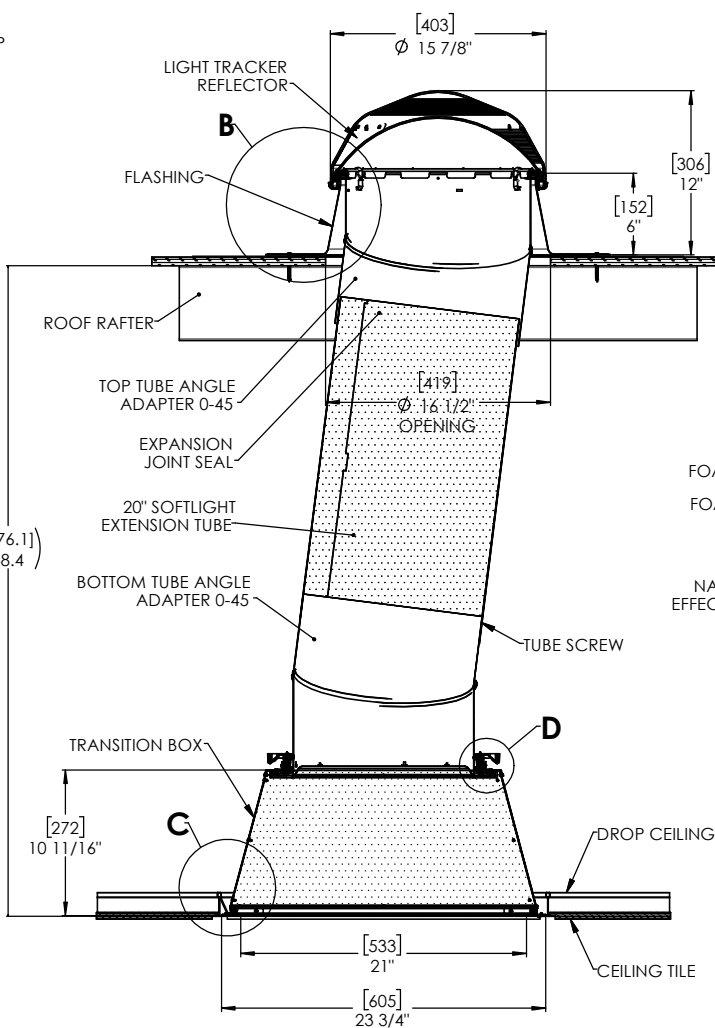

FULL SECTION
SCALE 1:1

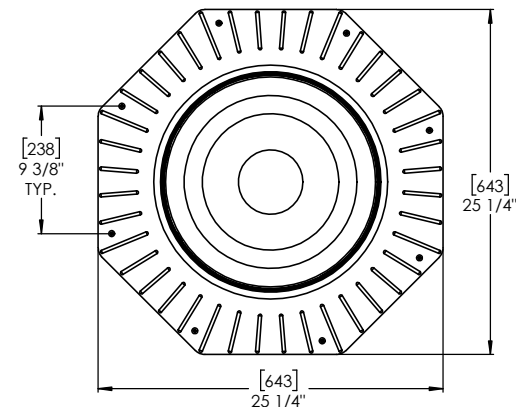

TOP VIEW

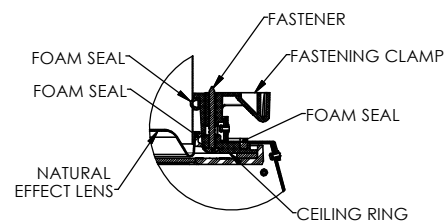

DETAIL D
SCALE 3 : 1

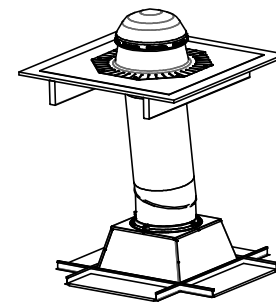

NOTES:

1. STRUCTURAL ELEMENTS (PLYWOOD, RAFTERS, DRYWALL ETC.) BY OTHERS & SHOWN FOR REFERENCE ONLY.
2. ALL TUBE JOINTS & SEAMS TAPED WITH 2" FOIL TAPE (NOT SHOWN).
3. DIMENSIONS IN BRACKETS ARE METRIC UNLESS OTHERWISE SPECIFIED.
4. 6" MIN CLEARANCE SHOULD BE MAINTAINED FROM ALL SOLATUBE COMPONENTS AND OTHER PLENUM COMPONENTS.

△ 30" MIN HEIGHT NEEDED FOR TRANSITION BOX

UNLESS OTHERWISE SPECIFIED:		SOLATUBE INTERNATIONAL INC. COPYRIGHT 2017 WWW.SOLATUBE.COM		 2210 OAK RIDGE HWY COSTA MESA, CA 92626 PH (714) 591-4400	
DIMENSION TOLERANCE FRACTIONS ± 1/8" INCH XX ± .06		DATE 3/17/17		TITLE: 300 DS SELF FLASHING SUSPENDED CEILING	
MATERIAL		DRAWN BY STEVENS	DATE	SIZE D	REV 2
FINISH		CHECKED BY	DATE	DWG. NO. 300DS-C-DAI-F6-TM-LN	
DO NOT SCALE DRAWING		APPROVED BY	DATE	SCALE: 1:1	
				SHEET 1 OF 1	