

**SOLATUBE M74 DS-O-DP-B-FC-OC  
(29 IN / 740 MM)  
CURB CAP  
OPEN CEILING**

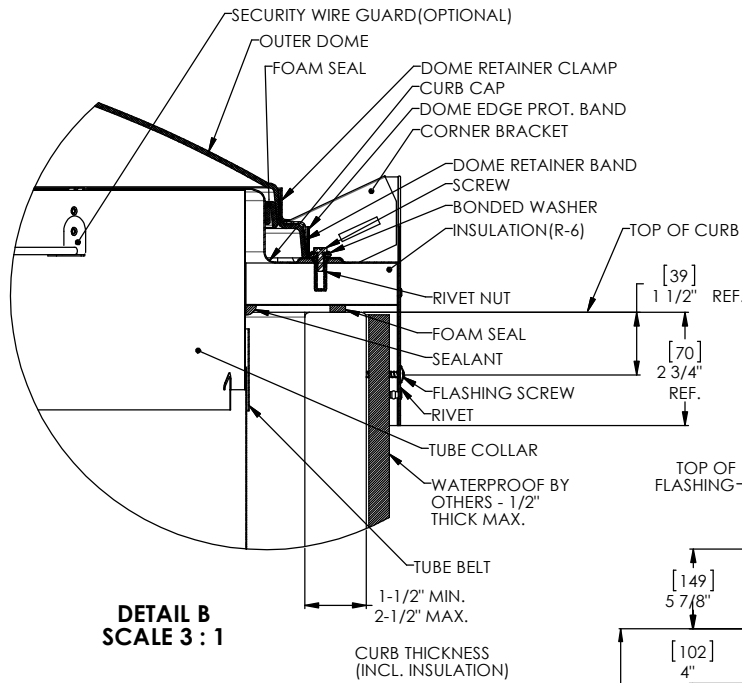

**DETAIL B  
SCALE 3 : 1**

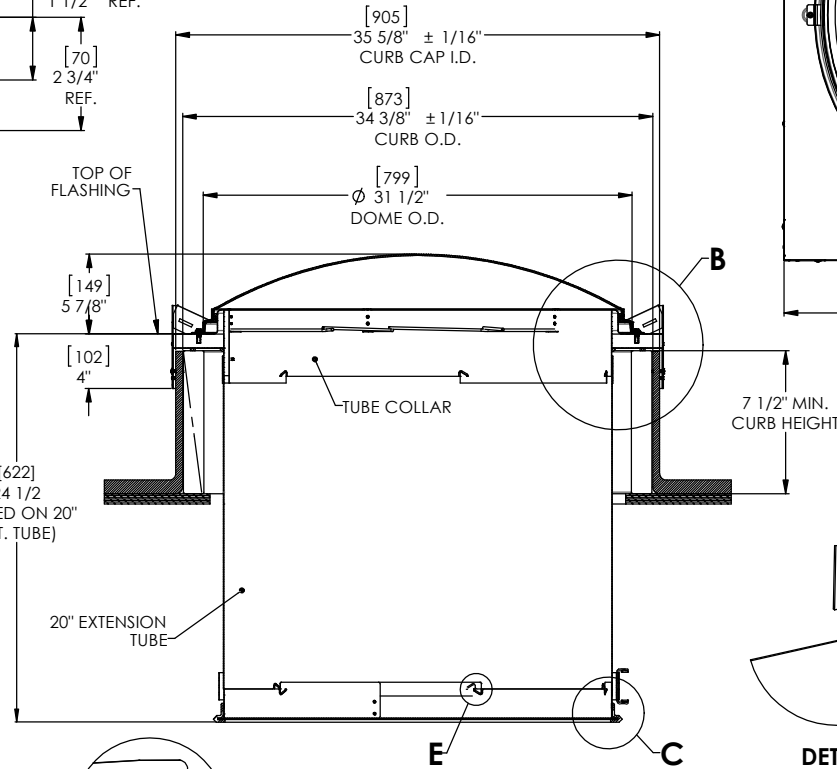

**SECTION A-A**

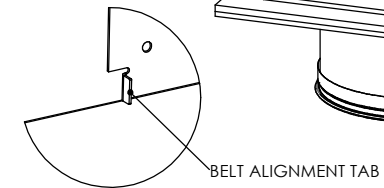
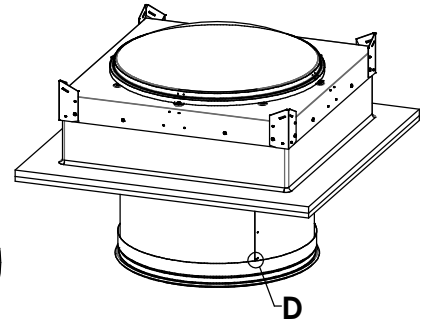
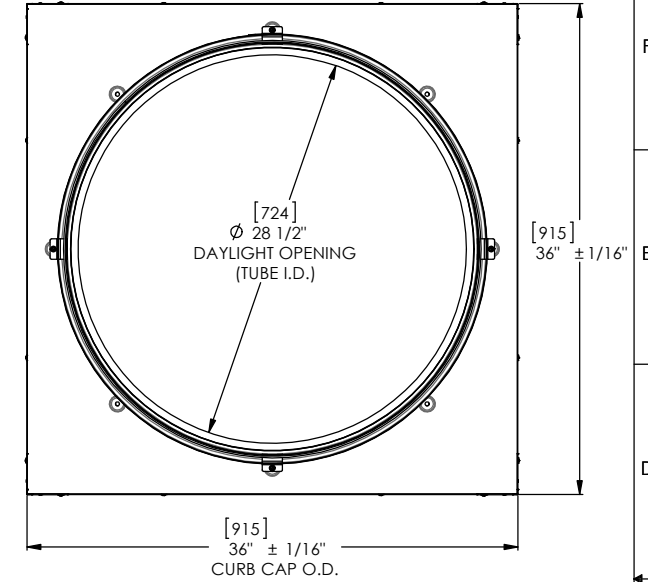

**DETAIL D  
SCALE 8 : 1**

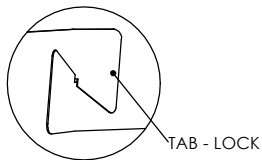

**DETAIL E  
SCALE 8 : 1**

**NOTES:**

1. STRUCTURAL ELEMENTS (PLYWOOD, RAFTERS, DRYWALL ETC.) BY OTHERS & SHOWN FOR REFERENCE ONLY.
2. DIMENSIONS IN BRACKETS ARE METRIC UNLESS OTHERWISE SPECIFIED.
3. 6" MIN CLEARANCE SHOULD BE MAINTAINED FROM ALL SOLATUBE COMPONENTS AND OTHER PLENUM COMPONENTS.
4. CURB CORNER TO CORNER MEASUREMENT SHALL BE EQUIVALENT TO WITHIN 3/32".

UNLESS OTHERWISE SPECIFIED:		SOLATUBE INTERNATIONAL INC. COPYRIGHT 2013 WWW.SOLATUBE.COM		 2015 DAK ROOPE WAY DUBLIN, CALIFORNIA 94568-6341 PH (925) 937-4400	
DIMENSION TOLERANCE FRACTIONS ± 1/4" BOTH MILLIMETER X ± 1 [X] ± 2.5 XX ± .06 [XX] ± 1.5		DRAWN BY STEVENS		DATE 20 MAY 13	
MATERIAL -		CHECKED BY -		DATE -	
FINISH -		APPROVED BY -		DATE -	
DO NOT SCALE DRAWING		-		-	
TITLE: <b>M74 DS CURB MOUNT OPEN CEILING</b>		SIZE <b>D</b>	DWG. NO. <b>M74DS-O-DP-B-FC-OC</b>	REV <b>3</b>	
SCALE: 1:1		SHEET 1 OF 1			