

DETAIL B
SCALE 3 : 1

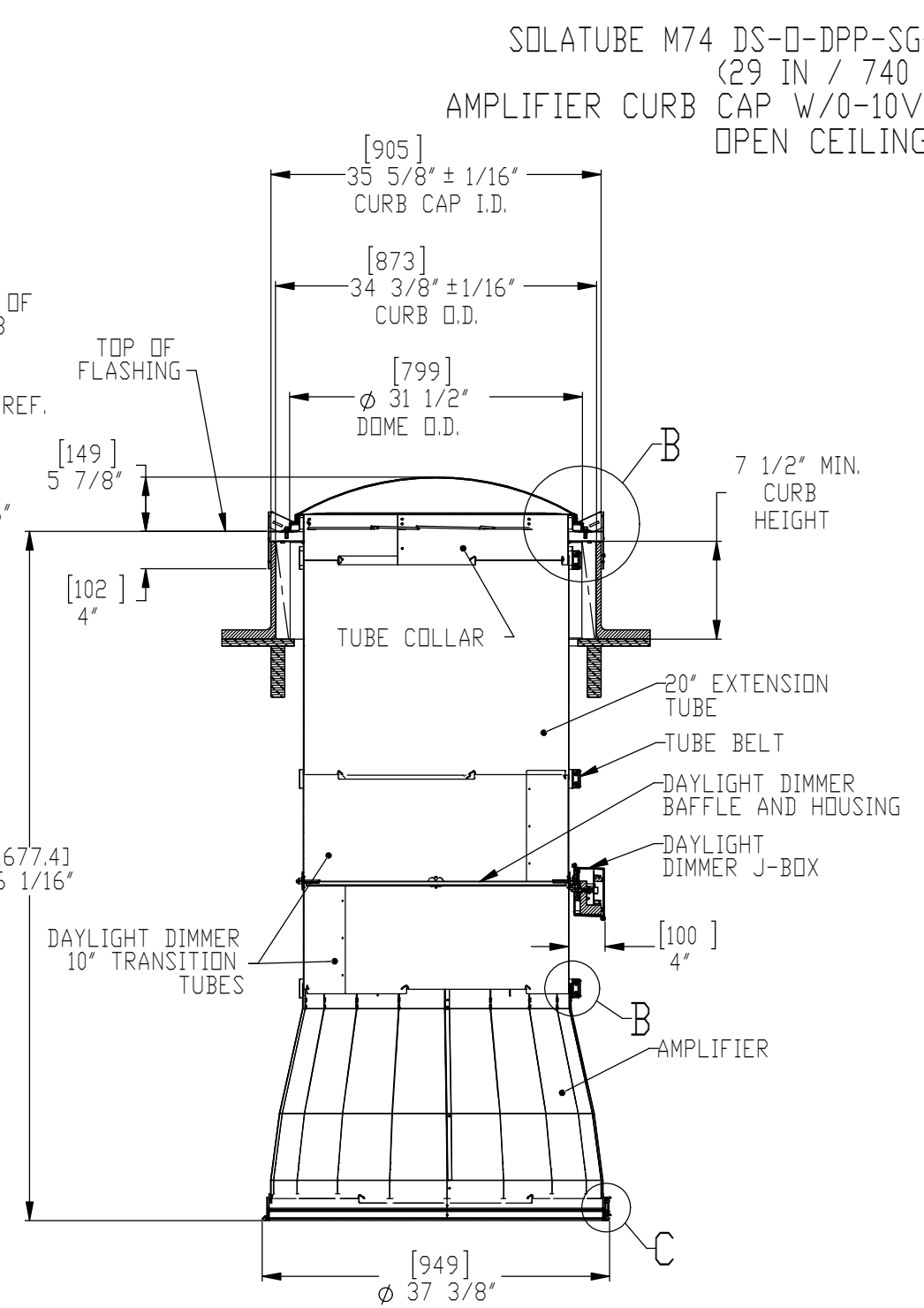

SECTION A-A
SCALE: 2:3

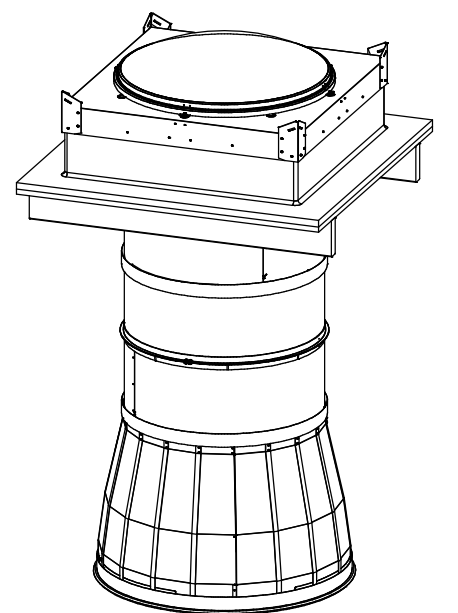
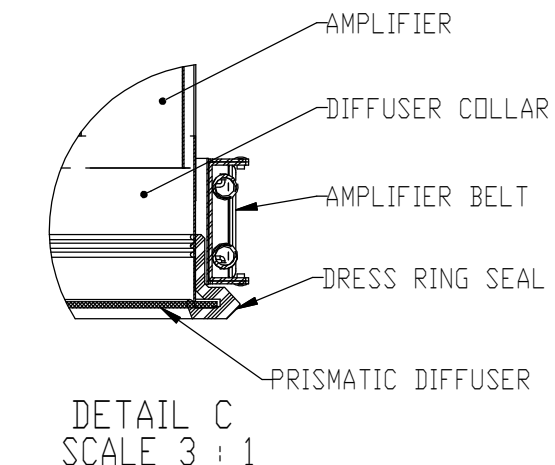
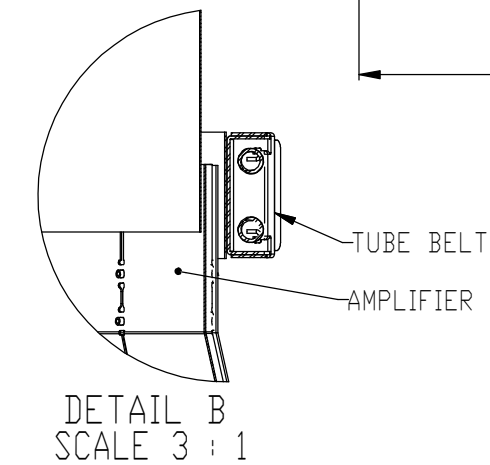
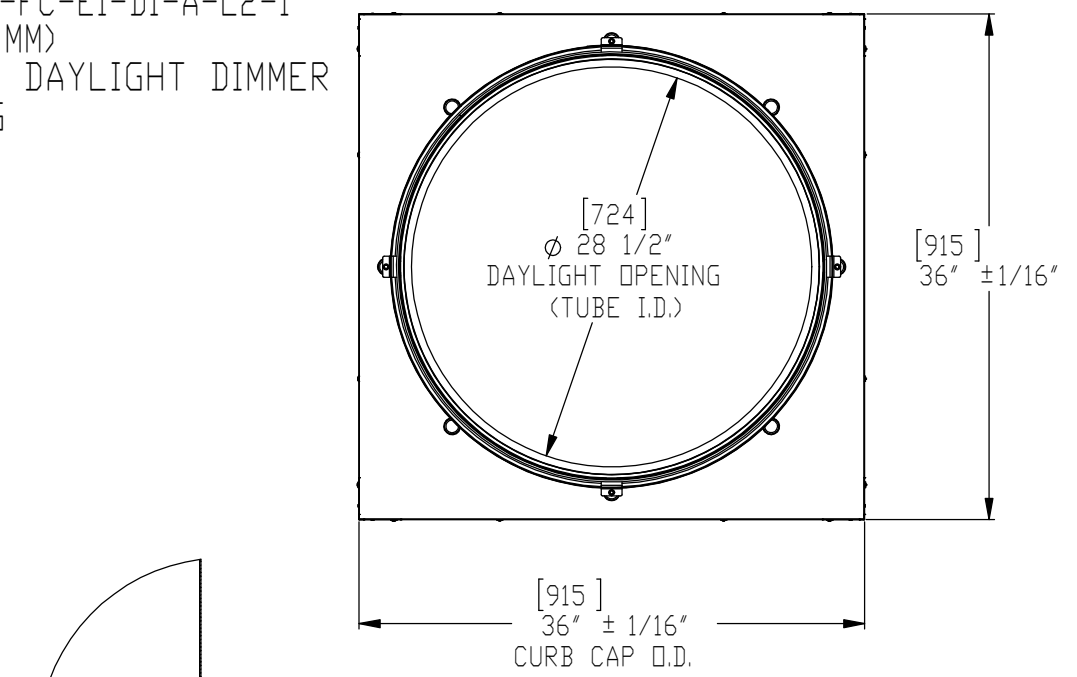

- NOTES:
- STRUCTURAL ELEMENTS (PLYWOOD, RAFTERS, DRYWALL ETC.) BY OTHERS & SHOWN FOR REFERENCE ONLY.
 - DIMENSIONS IN BRACKETS ARE METRIC UNLESS OTHERWISE SPECIFIED.
 - 6" MIN CLEARANCE SHOULD BE MAINTAINED FROM ALL SOLATUBE COMPONENTS AND OTHER PLENUM COMPONENTS.
 - CURB CORNER TO CORNER MEASUREMENT SHALL BE EQUIVALENT TO WITHIN 3/32".

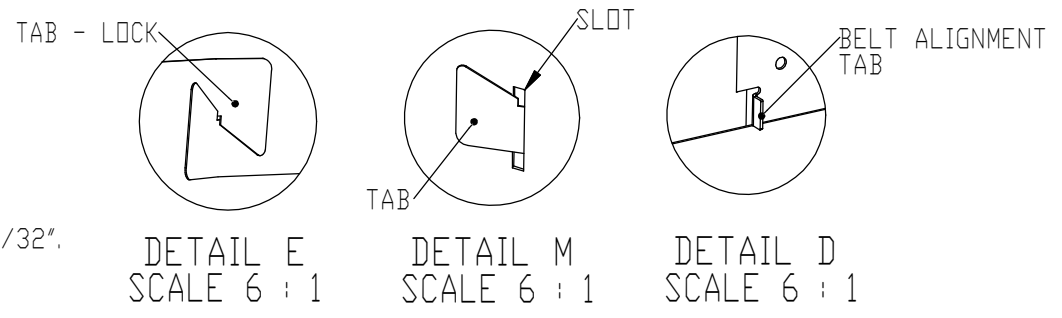

UNLESS OTHERWISE SPECIFIED:		<p>2210 OAK RIDGE WAY VISTA, CALIFORNIA 92081-8341 PH (760) 597-4400</p>	
DIMENSION TOLERANCE FRACTIONS ± 1/4" INCH .X ± .1 [X] ± 2.5 .XX ± .06 [XX] ± 1.5 MILLIMETER [X] ± 2.5 [XX] ± 1.5		SOLATUBE INTERNATIONAL, INC. COPYRIGHT 2013 WWW.SOLATUBE.COM	
MATERIAL	---	DRAWN BY	DATE
FINISH	---	CHECKED BY	DATE
DO NOT SCALE DRAWING		APPROVED BY	DATE
TITLE:		M74 DS CURB MOUNT DAYLIGHT DIMMER / AMPLIFIER	
SIZE	D	DWG. NO.	M74 DS-O-DPP-SG-FC-E1-D1-A-L2-I
SCALE:	1:1	REV	3
		SHEET 1 OF 1	