

SOLATUBE M74 DS-O-C-DP-FC-A
(29 IN / 740 MM)
HD COLLECTOR W/ CURB CAP AMPLIFIER
OPEN CIELING

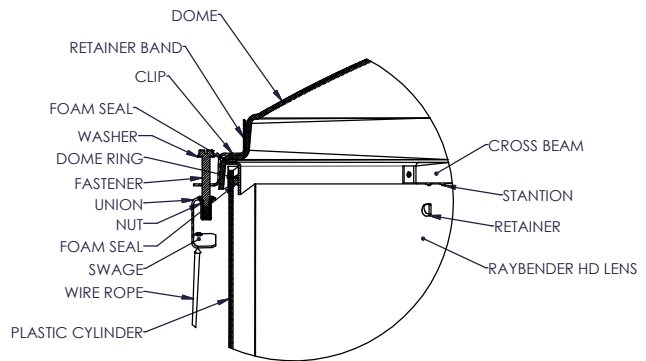

DETAIL C
SCALE 3 : 1

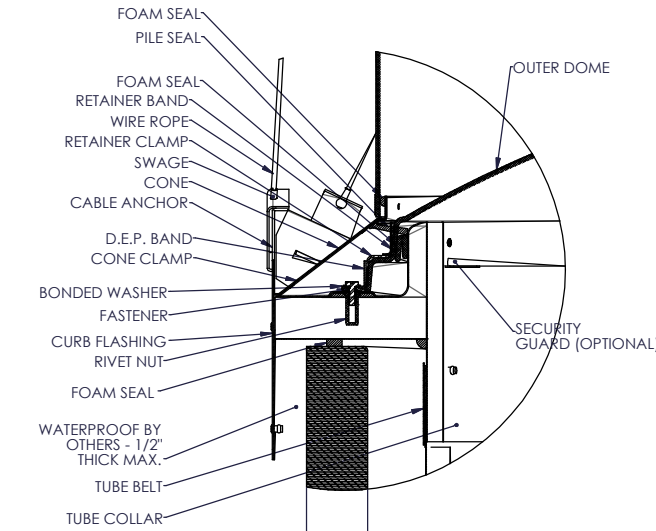

DETAIL B
SCALE 3 : 1

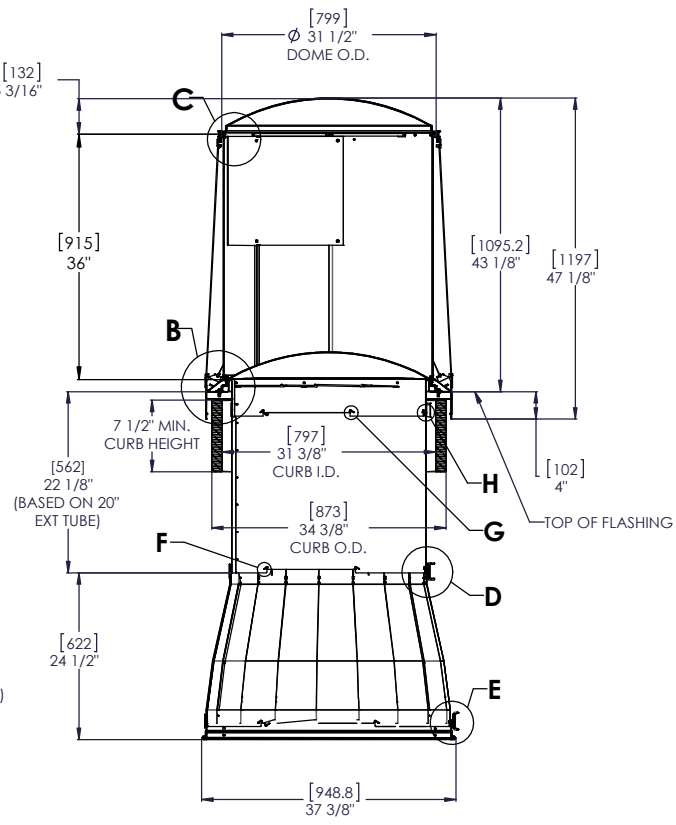

SECTION A-A
SCALE 1 : 2

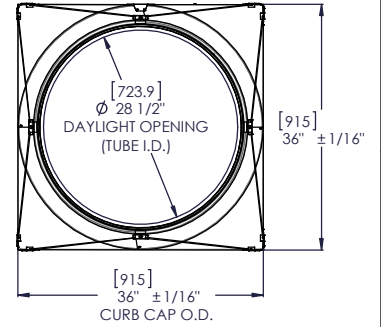

TOP VIEW

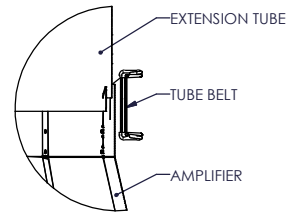

DETAIL D
SCALE 2 : 1

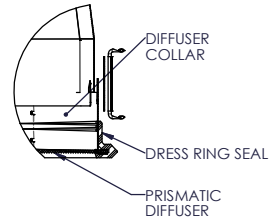

DETAIL E
SCALE 2 : 1

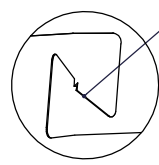
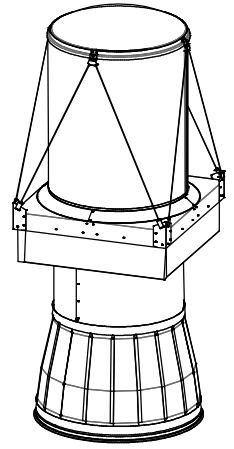

DETAIL G
SCALE 8 : 1

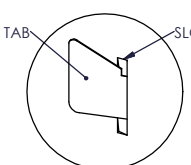

DETAIL F
SCALE 8 : 1

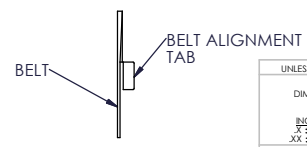

DETAIL H
SCALE 8 : 1

- NOTES:**
1. STRUCTURAL ELEMENTS (PLYWOOD, RAFTERS, DRYWALL ETC.) BY OTHERS & SHOWN FOR REFERENCE ONLY.
 2. ALL TUBE JOINTS & SEAMS TAPED WITH 2" FOIL TAPE (NOT SHOWN).
 3. DIMENSIONS IN BRACKETS ARE METRIC UNLESS OTHERWISE SPECIFIED.
 4. 6" MIN. CLEARANCE SHOULD BE MAINTAINED FROM ALL SOLATUBE COMPONENTS AND OTHER PLENUM COMPONENTS.

UNLESS OTHERWISE SPECIFIED:		 <small>2215 DAK ROOSE WAY COSTA MESA, CALIFORNIA 92626-1341 PH (714) 971-4400</small>	
DIMENSION TOLERANCE FRACTIONS ± 1/4" INCH ± 0.06" MILLIMETER XX ± 0.6" (XX) ± 1.5"		SOLATUBE INTERNATIONAL, INC. COPYRIGHT 2023 WWW.SOLATUBE.COM	
MATERIAL		DRAWN BY	DATE
FINISH		CHECKED BY	DATE
DO NOT SCALE DRAWING		APPROVED BY	DATE
		TITLE: M74 DS COLLECTOR RAYBENDER HD W/CURB FLASH & AMPLIFIER	
		DWG. NO. M74 DS-O-C-DP-FC-A	REV 2
		SCALE: 1:1	SHEET 1 OF 1