

SOLATUBE 750DS-CF-CCI
(21 IN / 530 MM)
CURB CAP W/ INSULATION

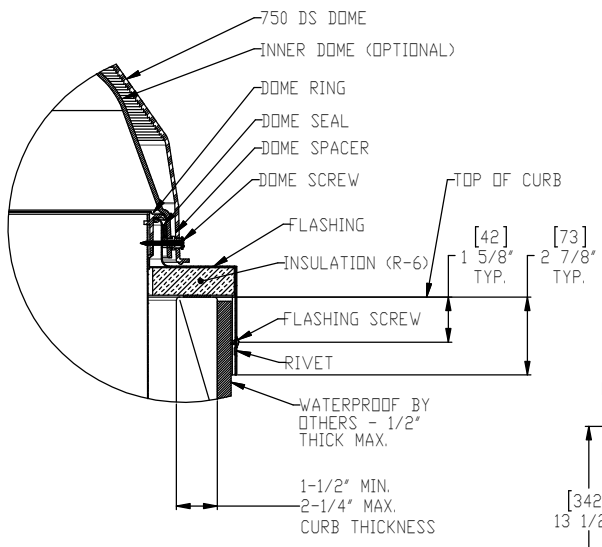

DETAIL B
SCALE 2 : 1

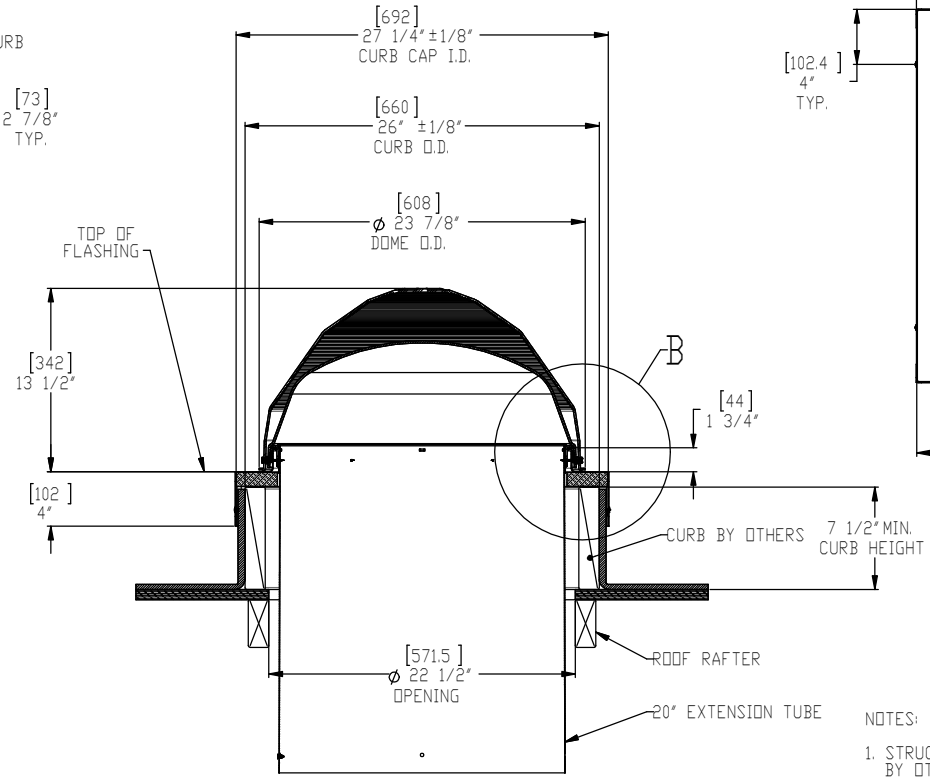

SECTION A-A

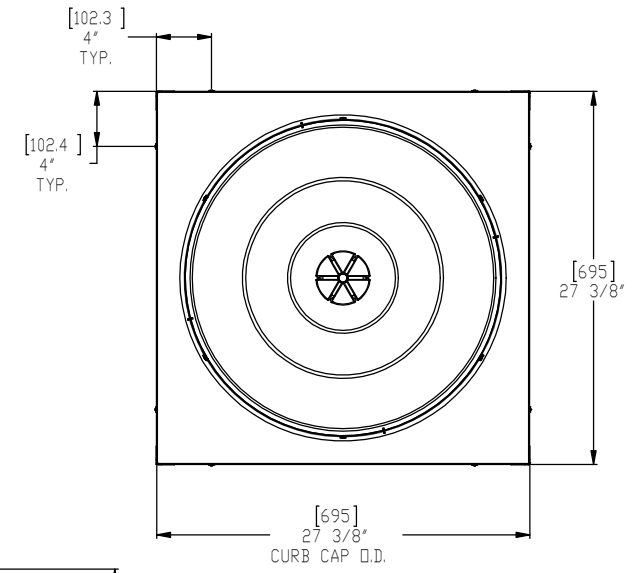

TOP VIEW

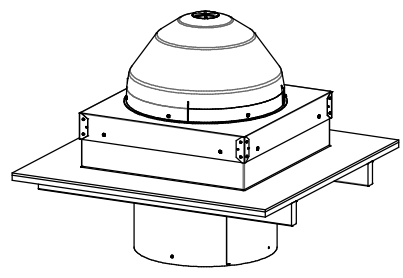

NOTES:

1. STRUCTURAL ELEMENTS (PLYWOOD, RAFTERS, DRYWALL ETC.) BY OTHERS & SHOWN FOR REFERENCE ONLY.
2. ALL TUBE JOINTS & SEAMS TAPED WITH 2" FOIL TAPE (NOT SHOWN).
3. DIMENSIONS IN BRACKETS ARE METRIC UNLESS OTHERWISE SPECIFIED.
4. 6" MIN CLEARANCE SHOULD BE MAINTAINED FROM ALL SOLATUBE COMPONENTS AND OTHER PLENUM COMPONENTS.

UNLESS OTHERWISE SPECIFIED		SOLATUBE INTERNATIONAL, INC. COPYRIGHT 2013 WWW.SOLATUBE.COM		 2015 DAKK ROOFE WY DORTCH, CALIFORNIA 92081-8341 PH (760) 971-4400	
DIMENSION TOLERANCE FRACTIONS ± 1/4" INCH MILLIMETER XX ± .05 (±.15)		DRAWN BY STEVENS		DATE 8/12/13	
MATERIAL ---		CHECKED BY ---		DATE ---	
FINISH ---		APPROVED BY ---		DATE ---	
DO NOT SCALE DRAWING		SIZE D		DWG. NO. 750DS-CF-CCI	
		SCALE: 1:1		REV 5	
				SHEET 1 OF 1	