

**SOLATUBE 330/750 DS  
(21 IN / 530 MM)  
330/750 DS LED LIGHT KIT**

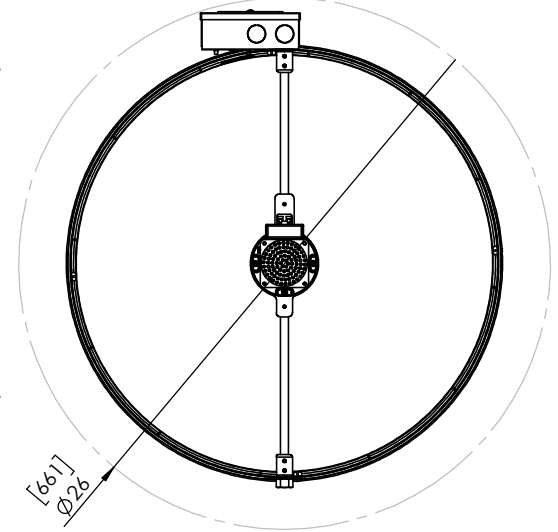
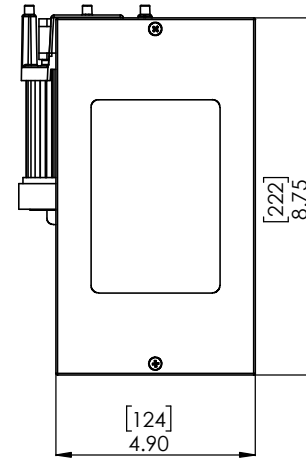
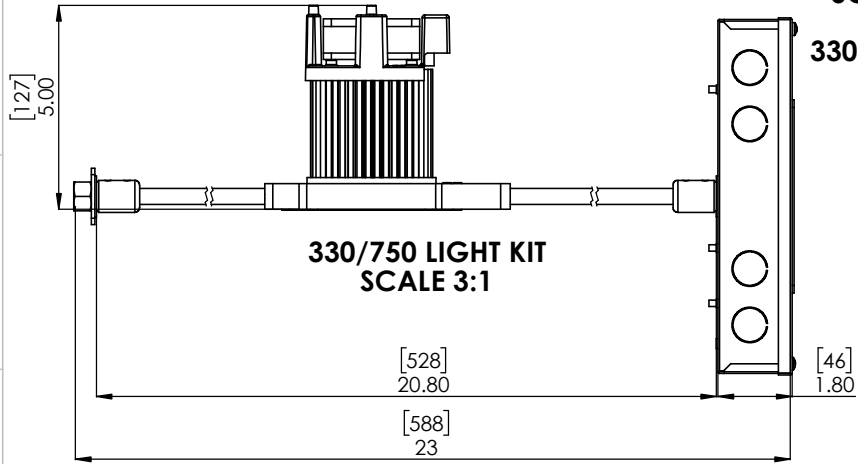

**TOP VIEW  
SCALE 3:2**

**330/750 DS CLOSED CEILING**

**330/750 DS OPEN CEILING**

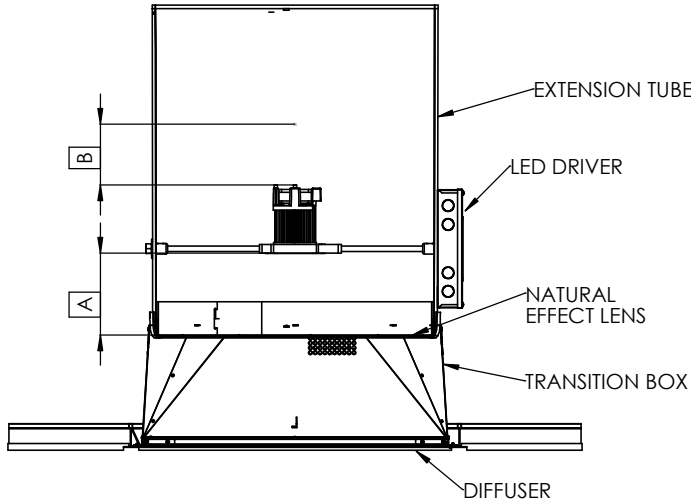

**FULL SECTION  
SCALE 1:1**

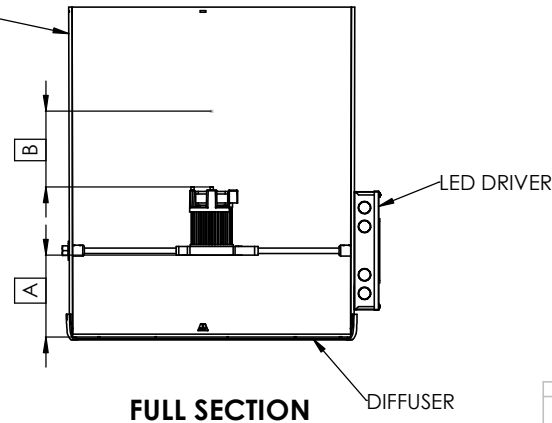

**FULL SECTION  
SCALE 1:1**

**A** BOTTOM OF LED MUST BE PLACED A MINIMUM OF 6" [152MM] FROM ANY LENS MATERIAL

**B** PLACE DAYLIGHT DIMMER A MINIMUM OF 4" [102MM] FROM TOP OF LED HEAT SINK IF INSTALLED IN CONJUNCTION WITH LED LIGHT KIT.

**NOTES:**

1. STRUCTURAL ELEMENTS (PLYWOOD, RAFTERS, DRYWALL ETC.) BY OTHERS & SHOWN FOR REFERENCE ONLY.
2. ALL TUBE JOINTS & SEAMS TAPED WITH 2" FOIL TAPE (NOT SHOWN).
3. DIMENSIONS IN BRACKETS ARE METRIC UNLESS OTHERWISE SPECIFIED.
4. 6" MIN. CLEARANCE SHOULD BE MAINTAINED FROM ALL SOLATUBE COMPONENTS AND OTHER PLENUM COMPONENTS.

UNLESS OTHERWISE SPECIFIED:		<b>SOLATUBE INTERNATIONAL, INC.</b> COPYRIGHT 2018 WWW.SOLATUBE.COM		 2215 ORR ROAD WAY DIGITAL, CALIFORNIA, 92081-8341 PH (760) 977-4400	
DIMENSION TOLERANCE FRACTIONS ± 1/8" INCH ± .015" MILLIMETER XX ± .06 (XX) ± 1.5		DRAWN BY KEIDENSCHNIK		DATE 6/10/2020	
FINISH		CHECKED BY		DATE	
DO NOT SCALE DRAWING		APPROVED BY		DATE	
TITLE: <b>330/750 DS LED LIGHT KIT</b>			SIZE	DWG. NO.	REV
SCALE: 1:20			D		1
			SHEET 1 OF 1		