

ICC Evaluation Service, Inc.
www.icc-es.org

Business/Regional Office ■ 5360 Workman Mill Road, Whittier, California 90601 ■ (562) 699-0543
Regional Office ■ 900 Montclair Road, Suite A, Birmingham, Alabama 35213 ■ (205) 599-9800
Regional Office ■ 4051 West Flossmoor Road, Country Club Hills, Illinois 60478 ■ (708) 799-2305

DIVISION: 08—DOORS AND WINDOWS
Section: 08620—Unit Skylights

REPORT HOLDER:

SOLATUBE INTERNATIONAL, INC.
2210 OAK RIDGE WAY
VISTA, CALIFORNIA 92081-8341
(760) 597-4400
www.solatube.com
info@solatube.com

EVALUATION SUBJECT:

**SOLATUBE TUBULAR DAYLIGHT DEVICE (TDD)
SKYLIGHTS**

1.0 EVALUATION SCOPE

Compliance with the following codes:

- 2006 *International Building Code*® (IBC)
- 2006 *International Residential Code*® (IRC)

Properties evaluated:

- Structural
- Durability
- Weather resistance

2.0 USES

The Solatube Tubular Daylight Devices described in this report are plastic-glazed tubular skylights complying with Chapters 24 and 26 of the IBC and UBC, and Section R308.6 of the IRC.

3.0 DESCRIPTION

Solatube TDD skylights consist of a light-transmitting dome with an optional internal curved reflector; a roof-mounted support base (flashing or curb); an upper-tube-supporting element (dome ring); reflective light-conducting tubing of either adjustable 0-to-30-degree elbows or 0-to-90 degree elbows, and/or straight tube extensions; a bottom-tube-supporting element (either ceiling ring or round-to-square plastic transition box); and a ceiling-mounted light-diffusing assembly (diffuser). The Solatube skylights have a maximum allowable air leakage of 0.3 cfm/ft² (1.5 L/s • m²). Solatube TDD skylights are available in 10-, 14- and 21-inch-diameter (254, 356 and 533 mm) sizes, identified as models 160 DS, 290 DS and SolaMaster/330DS, respectively. See Figures 1 and 2.

3.1 Domes for the 10- and 14-inch-diameter models (160 DS and 290 DS):

The 10- and 14-inch-diameter (254 or 356 mm) models are available with single acrylic and dual-glazed acrylic options. See Figure 1 and Table 1.

3.2 Domes for the 21-inch diameter model (SolaMaster/330DS):

The 21-inch-diameter (533 mm) model is available with single acrylic. See Figure 2 and Table 1.

3.3 Dome Rings:

Dome rings are used to connect the reflective tubing to the flashing and secure the dome. A reflector may be mounted inside the dome. Domes snap onto the dome ring for the 10-inch- and 14-inch-diameter (254 and 356 mm) models. Domes are mechanically fastened to the dome ring for the 21-inch-diameter (533 mm) model. See Figures 1 and 2.

3.4 Ceiling Rings:

Ceiling rings are used as mounting frames for the diffuser assemblies and to connect the light-conducting tubing to the tube-supporting ceiling for the 10- and 14-inch-diameter (254 or 356 mm) models. See Figure 1.

3.5 Round-to-square Transitions:

Round-to-square transitions are used to connect cylindrical tubing to a square aperture at the ceiling for suspended and framed ceiling applications for the 21-inch-diameter (533 mm) model. See Figure 2.

3.6 Flashing:

Pitched flashing is used for the 10- and 14-inch-diameter (254 or 356 mm) models. Nonpitched flashing or curb flashing is used with the 10-, 14- and 21-inch-diameter (254, 356 or 533 mm) models. Counter-flashing is used for the 10- and 14-inch-diameter (254 or 356 mm) models in tile roof applications. Turret extensions are available in lengths of 2, 4, 12, 24, 36 and 48 inches (51, 102, 305, 610, 914 and 1219 mm) for the 10- and 14-inch-diameter (254 and 356 mm) models, and 12, 24, 36 and 48 inches (305, 610, 914 and 1219 mm) for the 21-inch-diameter (533 mm) model. See Figures 1 and 2.

3.7 Diffusers:

The Optiview diffuser is a Class A polycarbonate material with a flame spread index not exceeding 25 and a smoke developed index not exceeding 450, when tested in accordance with ASTM E 84. Vusion lens and optional decorative diffuser attachments are Class C (Class III) acrylic materials with a flame spread index not exceeding 200 and a smoke developed index not exceeding 450, when tested in accordance with ASTM E 84. See Figures 1 and 2 and Table 1.

4.0 INSTALLATION

4.1 General:

Installation of the TDD skylights must comply with this report, the applicable code and the manufacturer's published installation instructions. See Figures 1 and 2 for details.

A 10.75-, 14.75- or 22-inch-diameter (273, 375 or 559 mm) round hole, for the 10-, 14- and 21-inch-diameter (254, 356 or

533 mm) skylights, respectively, must be cut in the roof sheathing and ceiling below the attic space. The sheathing must be minimum $\frac{5}{8}$ -inch-thick plywood complying with DOC PS 1 or DOC PS 2 or minimum 0.030-inch-thick steel deck having a minimum tensile strength of 45000 psi. The skylight support base must be attached to the plywood roof sheathing using eight No. 10 by 2-inch-long (51 mm) stainless steel or dactroized-finish (corrosion-resistant) steel sheet metal screws for the 10- and 14-inch-diameter (254 and 356 mm) models, and sixteen screws for the 21-inch-diameter (533 mm) model. The skylights are attached to metal roof decks with minimum No. 10 Teks screws, using the same number of fasteners as for wood decks. A felt or foam weather seal must be adhered to the top edge of the skylight support base for the 21-inch-diameter (533 mm) model. A polyurethane-based sealant must be used to seal the flashing or curb to the roof.

The reflective top tube with attached dome ring must be inserted into the skylight support base opening. A curved reflector may be mounted inside the dome. The dome ring must be secured to the support base using four No. 8 by 1-inch-long (25.4 mm) stainless steel, dactroized-finish (corrosion-resistant) or other corrosion-resistant steel pan or truss head sheet metal screws for the 10- and 14-inch-diameter (254 and 356 mm) units, and six No. 8 by $\frac{3}{4}$ -inch-long (19.1 mm) screws for the 21-inch-diameter (533 mm) unit. The 10- and 14-inch-diameter (254 and 356 mm) units terminate at the ceiling into the ceiling ring installed using six No. 6 by $\frac{15}{8}$ -inch-long (41 mm), corrosion-resistant, bugle head, drywall screws and/or four plastic self-locking anchors with No. 8 by $\frac{1}{2}$ -inch-long (38 mm), corrosion-resistant sheet metal screws or four plastic anchors/screws only. The 21-inch (533 mm) unit terminates at the ceiling into a round-to-square plastic transition box set into the framework on a suspended T-bar ceiling system, or must be installed into a gypsum ceiling using four No. 6 by $\frac{15}{8}$ -inch-long (41 mm), corrosion-resistant, bugle head drywall screws. The 10- and 14-inch-diameter (254 and 356 mm) light diffusers must be secured onto the ceiling ring by means of the Snap fit feature. The 21-inch-diameter (533 mm) light diffuser must be secured onto the square-to-round plastic transition box by means of four diffuser latches or, for the 21-inch-diameter (533 mm) open ceiling light diffuser, by means of the snap-in features.

The lowest edge of the support base turret opening must be at least 4 inches (102 mm) above the plane of the roof. This may be accomplished with installation of the optional Solatube 2- or 4-inch-high (51 or 102 mm) galvanized or aluminized-steel turret extension. The 4-inch (102 mm) clearance requirement and the turret extension are not required on roofs of IBC Group R-3 occupancy with a minimum slope of 3:12 (25%).

4.2 Tile Roofs:

For installation on a tile roof, a "dead-soft" 0.020-inch-thick (0.51 mm) pleated aluminum sheet must be used as malleable counter-flashing. After the appropriately sized hole for the 10- or 14-inch-diameter (254 and 356 mm) Solatube skylight is cut in the roof sheathing, a metal base flashing must be placed over the hole and secured in place using eight No. 10 by 2-inch-long (51 mm) stainless steel or dactroized-finish steel panhead sheet metal screws. See Figure 1 for additional details. Tiles surrounding the flashing are cut according to the profile of the flashing, with a maximum clearance of $\frac{1}{2}$ inch (12.7 mm) from the flashing. The pleated aluminum sheet,

with a circular hole cut in the center to match the flashing, must be placed over the flashing. A galvanized or aluminized steel turret extension ring must be placed over the opening of the base flashing, sandwiching the aluminum sheet between the flashing and turret extension ring. The aluminum sheet must then be secured to the top of the tiles in the course below using nonalkaline and nonacidic tile mastic. The remaining sheet must be tucked under the tiles in the upper course.

When installing the system with high-profile tiles, the upper and side edges of the pleated aluminum must be bent up to form a "bird stop" and water seal under the upper course tiles and surrounding field tiles.

4.3 Allowable Loads:

Under the IBC and IRC, the allowable inward (positive) and outward (negative) loads are 70 psf (3.33 kPa) in both directions for the 21-inch model and 70 psf (3.33 kPa) and 60 psf (2.87 kPa), respectively for both the 10- and 14-inch models.

5.0 CONDITIONS OF USE

The Solatube Tubular Daylight Devices described in this report comply with, or are suitable alternatives to what is specified in, those codes listed in Section 1.0 of this report, subject to the following conditions:

- 5.1 Installation must comply with this report, the manufacturer's published installation instructions and IBC Section 2405 and, IRC Section R308.6 as applicable. In the event of a conflict between the manufacturer's published installation instructions and this report, this report governs.
- 5.2 The maximum positive and negative allowable loads are as described in Section 4.3 of this report.
- 5.3 Where a Class A, B or C roof covering is required, skylight dome edges for the 10- and 14-inch-diameter (254 and 356 mm) skylights must be protected with the application of galvanized or aluminized steel dome-edge protective rings, as shown in Figure 1. Dome-edge protective rings are not required for the 21-inch-diameter (533 mm) skylights with 8- or 11-inch-high (203 or 279 mm) flashing, or any model with curb-mount flashing on curbs a minimum of 8 inches (203 mm) high.
- 5.4 Solatube TDD skylights are produced in Vista, California, under a quality control program with inspections by Underwriters Laboratories Inc. (AA-668).

6.0 EVIDENCE SUBMITTED

Data in accordance with the ICC-ES Acceptance Criteria for Plastic Skylights (AC16), dated February 2008.

7.0 IDENTIFICATION

The Solatube Tubular Daylight Devices described in this report must have a permanent label bearing the manufacturer's name (Solatube) and address; the product name; the name of the inspection agency (Underwriters Laboratories Inc.); the evaluation report number (ESR-2253); the plastic classification (CC-1 or CC-2); the thickness of the plastic glazing prior to forming. The 21-inch-diameter (533 mm) skylight must also have a safety label complying with Class 1, ANSI Standard Z35.1, warning of the risk of fall.

TABLE 1—SOLATUBE SKYLIGHT MATERIAL COMPONENTS

| COMPONENTS ¹ | MATERIAL | THICKNESS (inch) | SKYLIGHT MODEL | | |
|-------------------------------------|--------------------------------|---------------------|----------------|---------|---------|
| | | | 10-inch | 14-inch | 21-inch |
| Outer dome ² | Acrylic ¹ | 0.125 | X | X | — |
| Inner dome ² | Acrylic ¹ | 0.115 | X | X | — |
| Dome ² | Acrylic ¹ | 0.168 | — | — | X |
| Support base | Galvanized or aluminized steel | 0.030 | X | X | X |
| Turret extensions | Galvanized or aluminized steel | 0.030 | X | X | X |
| Round-to-square transition | PVC | 0.060 | — | — | X |
| Round-to-square transition | Acrylic | 0.100 | — | — | X |
| Dome edge protective ring | Galvanized or aluminized steel | 0.030 | X | X | X |
| Tile roof kit | Dead soft, pleated aluminum | 0.020 | X | X | — |
| Reflective tube | Aluminum | 0.015 | X | X | — |
| Reflective tube | Aluminum | 0.018 | — | — | X |
| Acrylic Light diffuser ² | Acrylic | 0.100 | X | X | X |
| Optiview diffuser ² | Polycarbonate | 0.022 | X | X | X |

For **SI**: 1 inch = 25.4 mm.

¹Plastic dome materials conform to products specified in the approved quality control manual..

²Classification CC-2.

³Classification CC-1.

⁴Thickness prior to thermoforming.

NOTE:
FLASHING PROVIDED BY SOLATUBE. WEATHERPROOFING DETERMINED BY SOLATUBE, GENERAL CONTRACTOR AND/OR PROFESSIONAL ROOFER AS REQUIRED

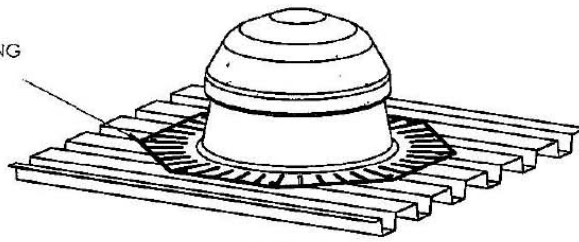

METAL ROOF
TYPE II OR III CONSTRUCTION
WITH STANDARD DIFFUSER ASSEMBLY

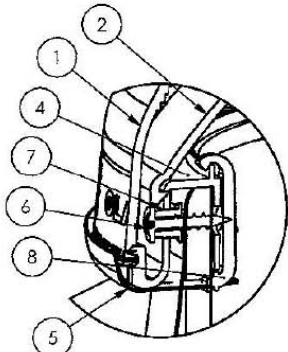

DOME ASSEMBLY
DETAIL A

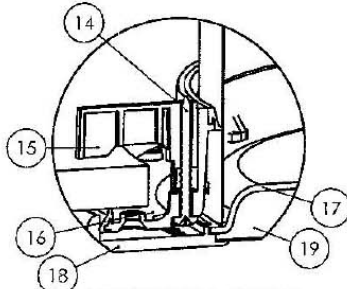

CEILING RING ASSEMBLY
DETAIL B

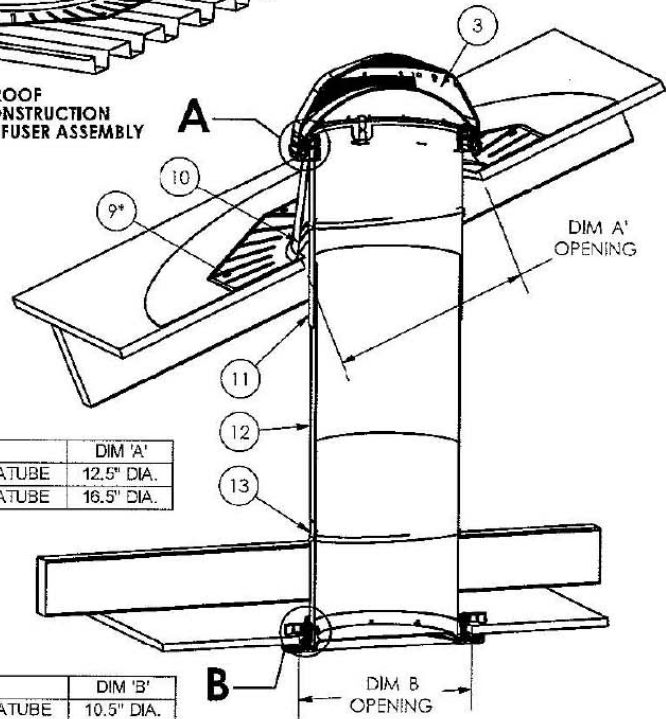

WOOD ROOF
TYPE IV OR V CONSTRUCTION

| | DIM 'A' |
|-----------------|------------|
| 160 DS SOLATUBE | 12.5" DIA. |
| 290 DS SOLATUBE | 16.5" DIA. |

| | DIM 'B' |
|-----------------|------------|
| 160 DS SOLATUBE | 10.5" DIA. |
| 290 DS SOLATUBE | 14.5" DIA. |



TURRET EXTENSION FOR FLASHING
(OPTIONAL)

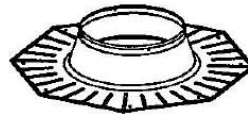

NO-PITCH FLASHING

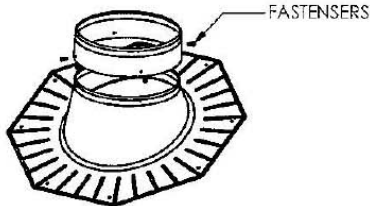

TURRET EXTENSION APPLICATION
SHOWN WITH PITCHED FLASHING

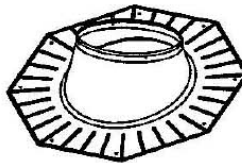

PITCHED FLASHING

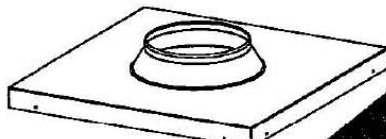

CURB FLASHING

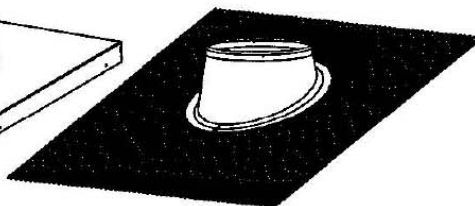

UNIVERSAL TILE FLASHING

| ITEM NO. | QTY. | DESCRIPTION |
|----------|------|---------------------------|
| 1 | 1 | OUTER DOME |
| 2 | 1 | INNER DOME |
| 3 | 1 | LIGHT TRACKER |
| 4 | 1 | DOME RING |
| 5 | 1 | DOME EDGE PROTECTION BAND |
| 6 | 4 | SCREW #8 X 1" |
| 7 | 4 | DOME RING SPACER |
| 8 | 4 | TOP TUBE CLIP |
| 9* | 8 | SCREW #10 X 2" SMS |
| 10 | 1 | FLASHING PITCHED |
| 11 | 1 | TOP TUBE |
| 12 | 1 | TUBE 16" EXTENSION |
| 13 | 1 | BOTTOM TUBE |
| 14 | 4 | SCREW #8 X 1.5" SMS |
| 15 | 4 | CLAMP |
| 16 | 1 | CEILING RING |
| 17 | 1 | DUAL GLAZE DIFFUSER |
| 18 | 1 | DRESS RING |
| 19 | 1 | DIFFUSER PANEL |

* USE (8) #10 TEK SCREWS FOR METAL ROOF

FIGURE 1—160 DS AND 290 DS SOLATUBE WITH DETAILS

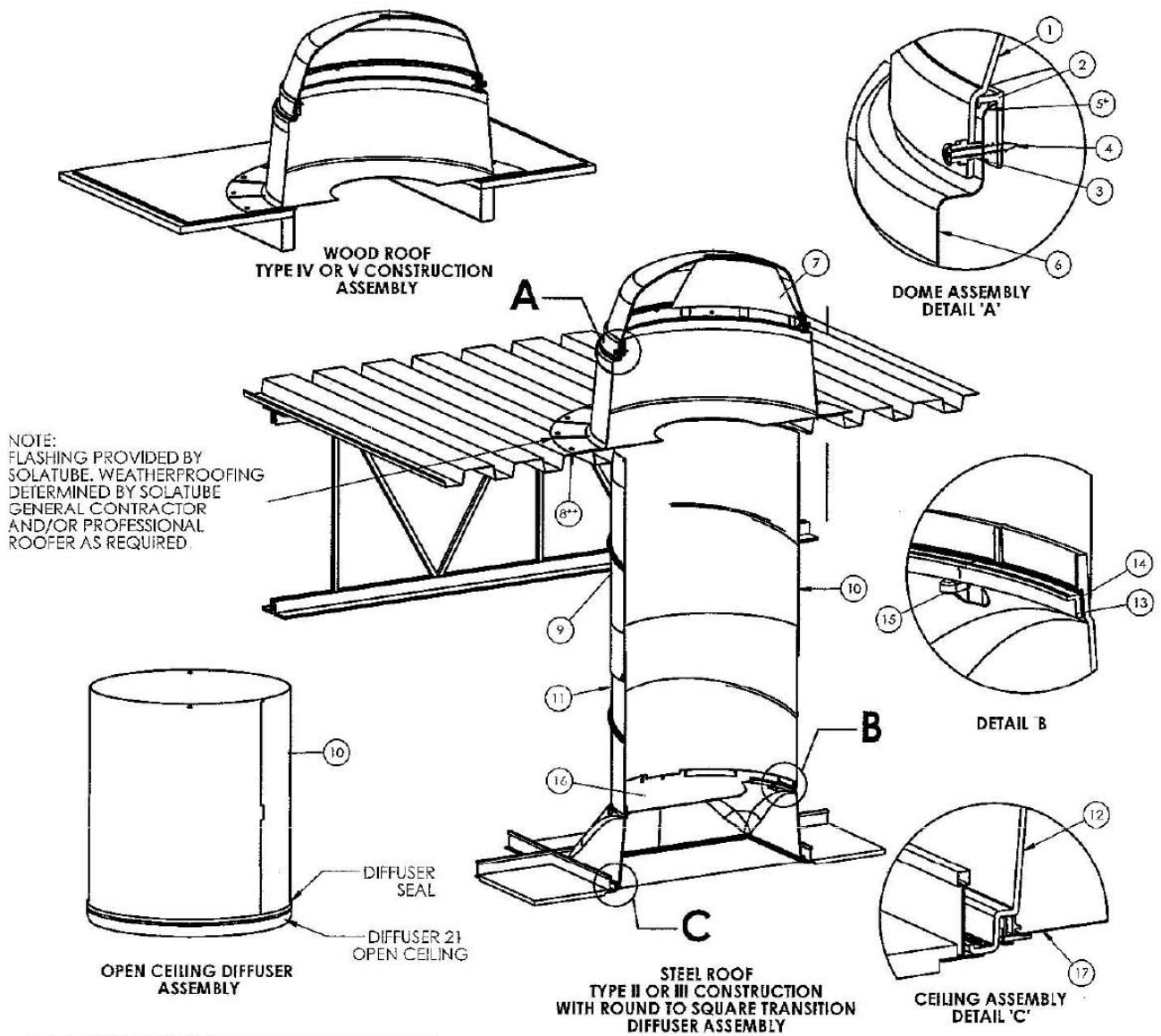

| ITEM NO. | QTY | DESCRIPTION |
|----------|-----|---------------------------|
| 1 | 1 | DOME 330 DS |
| 2 | 1 | DOME RING 21" |
| 3 | 6 | SPACER 21" |
| 4 | 6 | SCREW #8x1.5" SMS |
| 5* | 1 | GLAZING ROPE |
| 6 | 1 | FLASHING 21" |
| 7 | 1 | LITD 21" REFLECTOR |
| 8** | 16 | SCREW #10 X 2" SMS |
| 9 | 1 | TUBE 750 DS ANGLE ADAPTER |
| 10 | 1 | TUBE 24" EXTENSION 21" |
| 11 | 1 | TUBE BOTTOM 21" |
| 12 | 1 | RTS TRANSITION 21" |
| 13 | 1 | LENS RETAINER |
| 14 | 1 | LENS SEAL |
| 15 | 8 | RTS LENS TAB |
| 16 | 1 | NATURAL EFFECTS LENS |
| 17 | 1 | DIFFUSER 21" SQUARE |

* USE ONLY FOR OPEN CEILING APPLICATIONS
 ** USE (16) #10 TEK SCREWS FOR METAL ROOF

FIGURE 2—SOLAMASTER/330 DS WITH DETAILS